

Pistol Grip Air Drills

517D2M Series



400D3MP;5500;D1/2



517D2M;1000;D3/4

Output	Gear Ratio / Rated Speed	MODEL NUMBER	Output	Gear Ratio / Rated Speed	MODEL NUMBER
1/2" (13 mm) Drill Chuck	3:1 / 5500 RPM	400D3MP;5500;D1/2	1/2" (13 mm) Drill Chuck	16:1 / 1000 RPM	517D2M;1000;D1/2
	5:1 / 4200 RPM	400D5MP;4200;D1/2	3/4" (19 mm) Drill Chuck		517D2M;1000;D3/4
	8:1 / 2500 RPM	400D8MP;2500;D1/2			
	21:1 / 900 RPM	400D21MP;900;D1/2			
	36:1 / 550 RPM	400D36MP;550;D1/2			

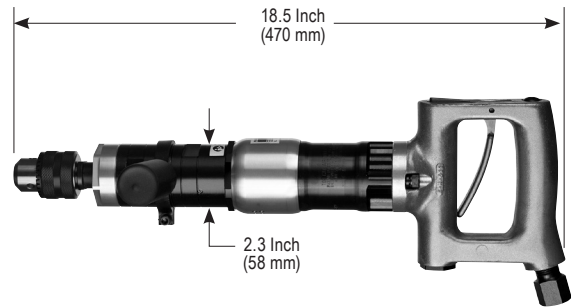
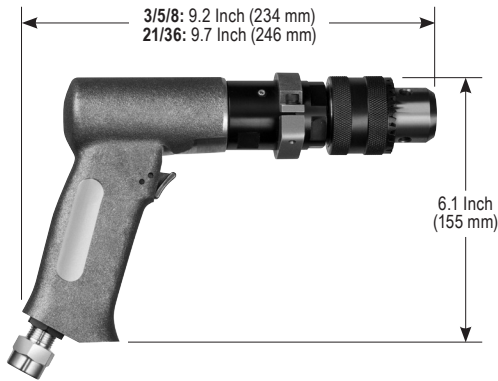

HP 1.2 H.P. (900 W)

Lbs 3/5/8: 4.4 Lbs. (2.0 Kg)
21/36: 4.6 Lbs (2.1 Kg)

cfm 35 cfm (16.5 L/s) Max

SUPPLY 3/8" NPT Inlet
1/2" (13mm) Hose Size

HP 1.5 H.P. (1125 W)

Lbs 11.0 Lbs. (5.0 Kg)

cfm 35 cfm (16.5 L/s) Max

SUPPLY 1/2" NPT Inlet
1/2" (13mm) Hose Size

STANDARD EQUIPMENT

- Tool
- Operating Instructions and Service Manual